

Pipe Technical Data Sheet

	18" DR 25 Fusible C-905®	18" DR 11 HDPE
Pipe Material	Fusible C-905®	HDPE
Total Pipe Length (LF)	1,000	1,000
Nominal Diameter (in)	18	18
Dimension Ratio	DR 25	DR 11
Series	DIPS	DIPS
Pressure Rating (PSIG)	165	160
Outside Diameter (in)	19.50	19.50
Inside Diameter (in)	17.85	15.74
Cross Sectional Flow Area (in ²)	250.1	194.6
Bend Radius (LF)	406	163
Tensile Strength (PSIG)	7,000	3,200
Safe Pulling Force (lbs)	128,400	108,600
Safe Pulling Stress (PSIG)	2,800	1,100
Relaxation Period (hrs)	0	24 - 48
Hydrostatic Design Basis (PSIG)	4,000	1,600
Critical Buckling Pressure (PSIG)	68	65
Connection to Host Pipe	Standard Mechanical Joint	Fused Flange/MJ Adapter
Material Weight (lbs/ft)	30.1	43.1
Total Pipe Weight (lbs)	30,081	43,073

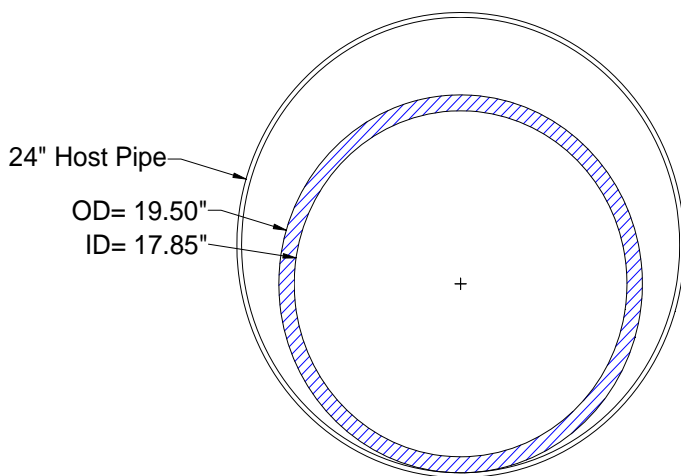

18" DR 25 Fusible C-905®

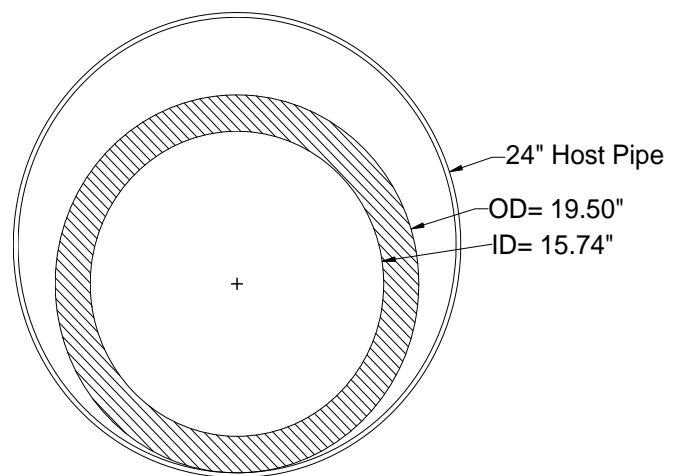

18" DR 11 HDPE